

SEGNA
LETICA
STRAD
ALE

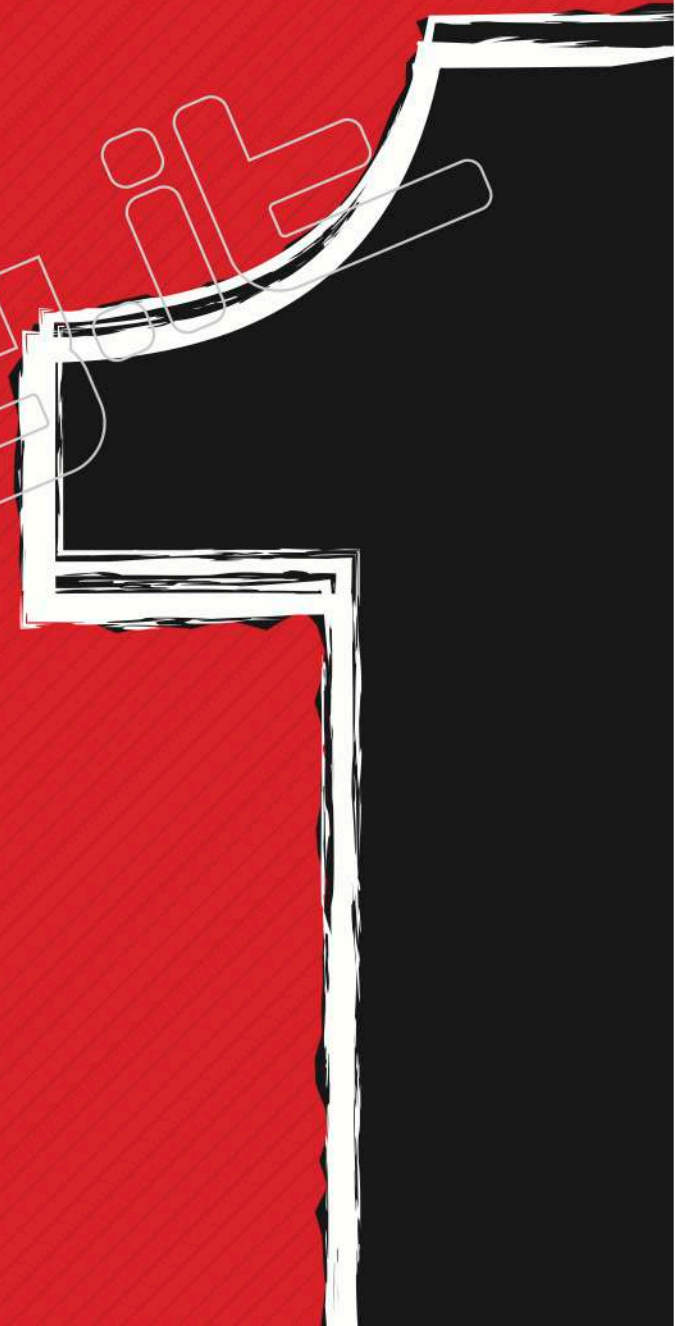



Tabella II 1 - Triangolo

DIMENSIONI (in cm)				
Formato	A _{esterno}	C	E	R
Piccolo	60	1	5,5	3
Normale	90	1,5	8	4,5
Grande	120	1,8	12	6

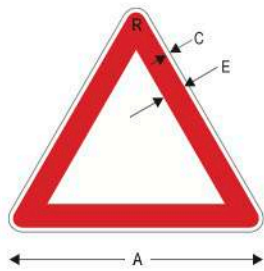

Tabella II 6 - Quadrato

DIMENSIONI (in cm)				
Formato	A _{esterno}	B	C	R
Piccolo	40	0,3	0,6	2,5
Normale	60	0,5	1	3,5
Grande	90	0,8	1,5	5,5

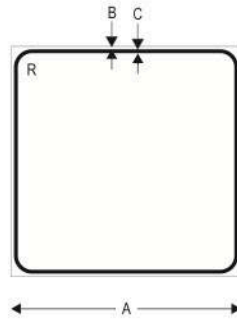

Tabella II 2 - Cerchio "divieto"

DIMENSIONI (in cm)			
Formato	C	D	E
Piccolo	0,8	40	5
Normale	1	60	7,5
Grande	1,5	90	11

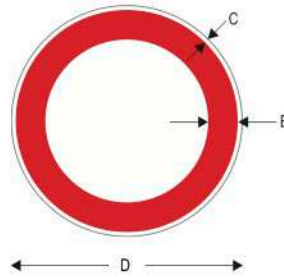

Tabella II 5 - Quadrato (dispositivo con diagonale verticale)

DIMENSIONI (in cm)						
Formato	A _{esterno}	B	C	Q	R	S
Piccolo	40	0,3	0,6	25	2,5	0,6
Normale	60	0,5	1	40	3,5	1
Grande	90	0,8	1,5	60	5,5	1,5

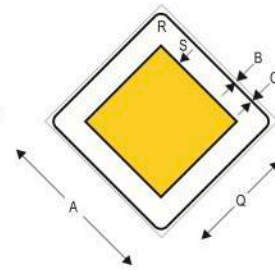

Tabella II 2 - Cerchio "obbligato"

DIMENSIONI (in cm)		
Formato	C	D
Piccolo	0,8	40
Normale	1	60
Grande	1,5	90

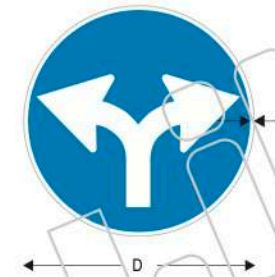

Tabella II 4 - Ottagono

DIMENSIONI (in cm)				
Formato	A	B	C	D
Piccolo	60	20	2	50
Normale	90	30	3	75
Grande	120	40	4	100

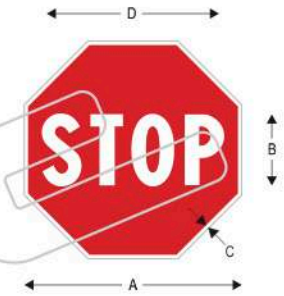

Tabella II 7 - Rettangolare "ingliesione"

DIMENSIONI (in cm)					
Formato	A _{esterno}	B	C	D	R
Ridotto	40	60	0,8	0,4	3
Piccolo	60	90	1,2	0,6	4,5
Normale	90	125	1,6	0,8	7
Grande	135	200	2,6	1,3	10

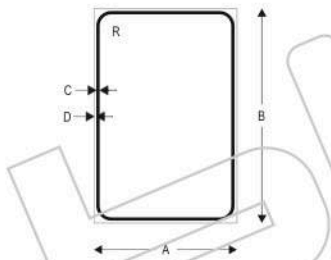

Tabella II 8 - Rettangolare "servizi"

DIMENSIONI (in cm)						
Formato	A _{esterno}	B	C	D	Q	R
Piccolo	40	60	0,8	0,4	30	3
Normale	60	90	1,2	0,6	45	4,5
Grande	90	135	1,6	0,8	65	7

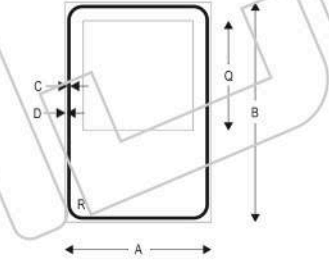

Tabella II 9 - Pannello integrativo di segnali quadrati o rettangolari

DIMENSIONI (in cm)				
Formato	A	B	C	R
Ridotto	40	0,3	0,6	2,5
Piccolo	60	0,5	1	3,5
Normale	90	0,8	1,5	5,5
Grande	135	1	2	8,5

* nel caso di pannello rettangolare l'altezza sarà 1/3 del lato maggiore

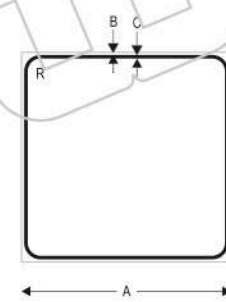

Tabella II 11 - Pannello integrativo di segnali circolari

DIMENSIONI (in cm)					
Formato	A	B	C	D	R
Piccolo	33	0,3	0,6	17	2
Normale	50	0,4	0,8	25	3
Grande	75	0,5	1	33	4

* nel caso di pannello quadrato D=A

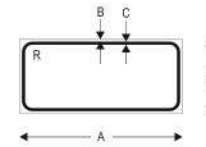

Tabella II 10 - Pannello integrativo di segnali triangolari

DIMENSIONI (in cm)					
Formato	A	B	C	D	R
Piccolo	53	0,3	0,6	18	2
Normale	80	0,4	0,8	27	3
Grande	105	0,5	1	35	4

* nel caso di pannello quadrato D=A

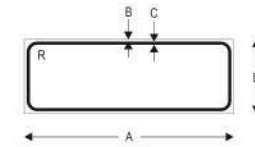

Tabella II 12 - Pannello integrativo modello 5

DIMENSIONI (in cm)					
Formato	A	B	C	D	R
Piccolo	10	0,2	0,4	25	2
Normale	15	0,3	0,6	35	2,5
Grande	25	0,4	0,8	50	3

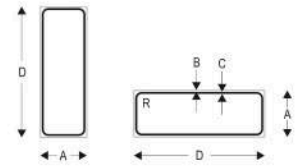

Tabella II 13/a - Segnali di direzione urbani

DIMENSIONI (in cm) - iscrizioni su una sola riga

Formato	A	B	C	D	E	F	G	H	L	M
Piccolo	18,5	15,5	1,5	1,5	2	4	5,25	20	100	8
Normale	23	18	2	2,5	3	4	6,5/7,5	25	125	10/8
Grande	27,5	21,5	2,5	3	3	4	7,75	30	150	12

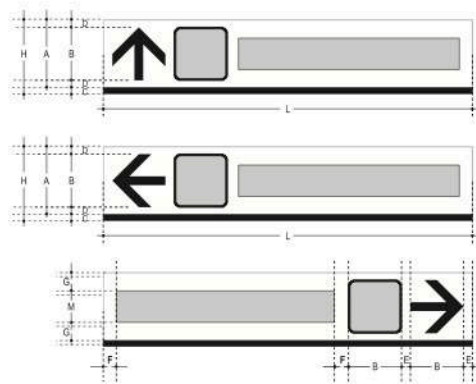

Tabella II 14/a - Segnali di direzione extraurbani

DIMENSIONI (in cm) - iscrizioni su una sola riga

Formato	C	D	E	H	L	M	N	R ₁	R ₂	R ₃	P	S
Piccolo	1	0,5	17	33	130	14	12	6	10	1,5	5	28,5
Normale	1,5	1	22	40	150	18	15,2	8	13	2	6,5	38
Grande	3	1,5	38	70	250/450	32	27	14	23	2,5	11,5	60

N.B. le cifre sono arrotondate per difetto o per eccesso al millimetro

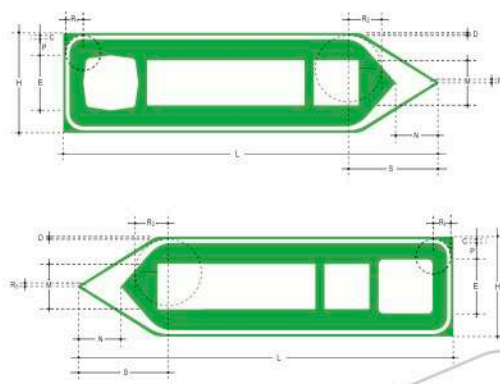

Tabella II 14/b - Segnali di direzione extraurbani

DIMENSIONI (in cm) - iscrizioni su una sola riga

Formato	C	D	E	H	L	M	N	R ₁	R ₂	R ₃	P	S	F	G
Piccolo	1,5	1	22	40	150	12	15,5	8	13	2	6,5	38	3	5
Normale	2	1	27	50	170	14	20	11	16	2	8,5	48	4,5	7
Grande	3	1,5	38	70	250/400	20	27	14	23	2,5	11,5	60	6	9

N.B. le cifre sono arrotondate per difetto o per eccesso al millimetro

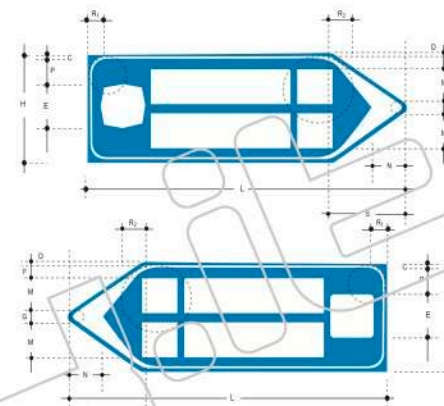

Tabella II 13/b - Segnali di direzione urbani

DIMENSIONI (in cm) - iscrizioni su due righe

Formato	A	B	C	D	E	F	G	H	L	M	M
Piccolo	28	15,5	2	6,25	3	4	3,5	30	100	8	5
Normale	32,5	18	2,5	7,25	3	4	4	35	125	10	4,5
Grande	37	21,5	3	7,75	3	4	4	40	150	12	5

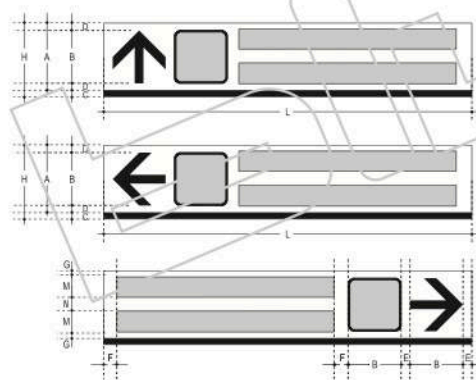

Tabella II 15 - Segnali nome - strada

DIMENSIONI (in cm)

Formato	H	h ₁	h ₂	L
Piccolo	20	8	6	60-80
Normale	25	10	8	80-100
Grande	30	12	10	100-120-140

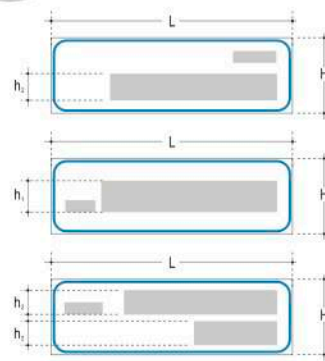
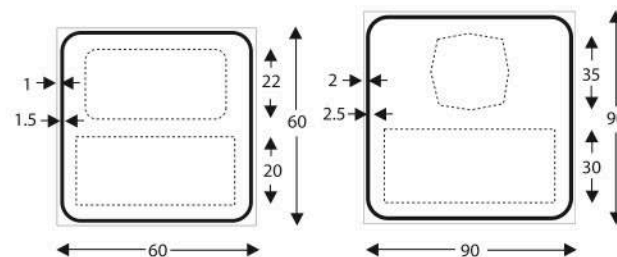

Segnali per Cavalcavia (Autostrade e strade statali)



fig. 1
strada deformata



fig. 2
dosso



fig. 3
cunetta



fig. 4
curva a destra



fig. 5
curva a sinistra



fig. 6
doppia curva,
la prima a destra



fig. 7
doppia curva,
la prima a sinistra

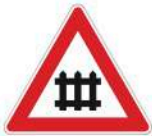

fig. 8
passaggio a livello
con barriere



fig. 9
passaggio a livello
senza barriere



fig. 12
attraversamento
tranviario



fig. 13
attraversamento
pedonale



fig. 14
attraversamento
ciclabile



fig. 15
discesa
pericolosa



fig. 16
salita ripida



fig. 17
strettoia
simmetrica



fig. 18
strettoia asimmetrica
a sinistra



fig. 19
strettoia asimmetrica
a destra



fig. 20
ponte mobile



fig. 21
banchina pericolosa



fig. 22
strada sdruciolevole



fig. 23
bambini



fig. 24
animali domestici
vaganti



fig. 25
animali selvatici
vaganti



fig. 26
doppio senso di
circolazione



fig. 27
circolazione
rotatoria



fig. 28
sbocco su molo
o su argine



fig. 29
materiale instabile
sulla strada



fig. 30.a
caduta massi



fig. 30.b
caduta massi



fig. 31.a
semaforo



fig. 31.b
semaforo



fig. 32
aeromobili



fig. 33
forte vento
laterale



fig. 34
pericolo di
incendio



fig. 35
altri pericoli



fig. 10.a
croce
di S. Andrea



fig. 10.b
doppia croce
di S. Andrea



fig. 10.c
croce
di S. Andrea
installata
verticalmente



fig. 10.d
doppia croce
di S. Andrea
installata
verticalmente



fig. 11.a
1° pannello
distanziometrico



fig. 11.b
2° pannello
distanziometrico



fig. 11.c
3° pannello
distanziometrico

segnali di precedenza



fig. 36
dare precedenza
obbligatorio
in pellicola cl.2



fig. 37
fermarsi e dare
precedenza
obbligatorio
in pellicola cl.2



fig. 38
preavviso di dare
precedenza



fig. 39
preavviso di
fermarsi e dare
precedenza



fig. 40
intersezione con
precedenza a destra
obbligatorio
in pellicola cl.2



fig. 41
dare precedenza
nei sensi unici
alternati



fig. 42
fine del diritto di
precedenza



fig. 43.a
intersezione con
diritto di
precedenza



fig. 43.b
intersezione a T
con diritto di
precedenza



fig. 43.c
intersezione a T
con diritto di
precedenza



fig. 43.d
confluenza a
destra



fig. 43.e
confluenza a
sinistra



fig. 44
diritto di
precedenza



fig. 45
diritto di precedenza
nei sensi unici
alternati



fig. 46
divieto di transito



fig. 47
senso vietato



fig. 48
divieto di sorpasso
*obbligatorio
in pellicola cl.2*



fig. 49
distanziamento
minimo
obbligatorio
di ... metri



fig. 50
limite massimo di
velocità di ... km/h



fig. 51
divieto di
segnalazioni
acustiche



fig. 52
divieto di sorpasso per
veicoli di massa a pieno
carico superiore a 3,5 t.
obbligatorio in pell. cl.2



fig. 53
transito vietato ai
veicoli a trazione
animale



fig. 54
transito vietato
ai pedoni



fig. 55
transito vietato
alle biciclette



fig. 56
transito vietato
ai motocicli



fig. 57
transito vietato
ai veicoli a braccia



fig. 58
transito vietato
a tutti gli autoveicoli



fig. 59
transito vietato
agli autobus



fig. 60.a
transito vietato
ai veicoli di massa
a pieno carico
superiore a 3,5 t.



fig. 60.b
transito vietato
ai veicoli di massa
a pieno carico
superiore a t.



fig. 61
transito vietato ai
veicoli a motore
trainanti un
rimorchio



fig. 62
transito vietato
alle macchine
agricole



fig. 63
transito vietato ai
veicoli che
trasportano merci
pericolose



fig. 64.a
transito vietato ai
veicoli che
trasportano esplosivi
o prodotti facilmente
inflammabili



fig. 64.b
transito vietato ai
veicoli che
trasportano prodotti
susceptibili di
contaminare l'acqua



fig. 65
transito vietato
ai veicoli aventi
larghezza
superiore a ... metri



fig. 66
transito vietato
ai veicoli aventi
altezza superiore
a ... metri



fig. 67
transito vietato ai veicoli
o complessi di veicoli
aventi larghezza superiore
a ... metri



fig. 68
transito vietato
ai veicoli aventi
una massa
superiore a ... t.



fig. 69
transito vietato
ai veicoli aventi
una massa per asse
superiore a ... t.



fig. 70
via libera



fig. 71
fine
limitazione
di velocità

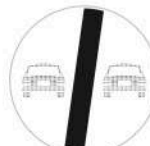

fig. 72
fine
del divieto
di sorpasso



fig. 73
fine del divieto
di sorpasso per
i veicoli di massa
superiore a 3,5 t.



fig. 74
divieto di sosta



fig. 75
divieto di fermata

articoli non inseriti nel codice della strada



fig. 78
passo carrabile



fig. 79.a
sosta consentita
a particolari
categorie



fig. 79.b
sosta consentita
a particolari
categorie



fig. 79.c
sosta consentita
a particolari
categorie



fig. 79.d
regolazione
flessibile
della sosta in
centro abitato



ex mod. 25.r

segnali di indicazione



fig. 76
parcheggio



fig. 77
preavviso di
parcheggio



art. 77.a
preavviso di
parcheggio



art. 77.b
preavviso di
parcheggio



art. 77.c
parcheggio
con freccia di
direzione



art. 77.d
parcheggio
con freccia di
direzione



art. 77.e
parcheggio
con freccia di
direzione



art. 77.g



art. 77.h



art. 77.i

segnali di obbligo e di indicazione



fig. 80.a

direzione obbligatoria diritto



fig. 80.b

direzione obbligatoria a sinistra



fig. 80.c

direzione obbligatoria a destra



fig. 80.d

preavviso di direzione obbligatoria a destra



fig. 80.e

preavviso di direzione obbligatoria a sinistra



fig. 81.a

direzioni consentite destra e sinistra



fig. 81.b

direzioni consentite diritto e destra



fig. 81.c

direzioni consentite diritto e sinistra



fig. 82.a

passaggio obbligatorio a sinistra



fig. 82.b

passaggio obbligatorio a destra



fig. 83

passaggi consentiti



fig. 84

rotatoria



fig. 85

limite minimo di velocità



fig. 86

fine del limite minimo di velocità

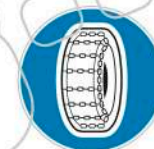

fig. 87

catene per neve obbligatorie



fig. 88

percorso pedonale



fig. 89

fine del percorso pedonale



fig. 90

pista ciclabile



fig. 91

fine pista ciclabile



fig. 92.a

pista ciclabile contigua al marciapiede



fig. 92.b

percorso pedonale e ciclabile



fig. 93.a

fine della pista ciclabile contigua al marciapiede



fig. 93.b

fine del percorso pedonale e ciclabile



fig. 94

percorso riservato ai quadrupedi da soma o da sella



fig. 95

fine del percorso riservato ai quadrupedi da soma o da sella



fig. 96

alt - dogana



fig. 97.a

confine di stato tra paesi della comunità europea



fig. 97.b

preavviso di confine di stato tra paesi della comunità europea



fig. 98

alt - polizia



fig. 99

alt - stazione



fig. 100
centro



fig. 101
poste



fig. 102
comune



fig. 103
pronto
soccorso



fig. 104
ospedale



fig. 105
ambulatorio



fig. 106
farmacia



fig. 107
telefono



fig. 108
informazioni



fig. 109
carabinieri



fig. 110.a
polizia



fig. 110.b
guardia
di finanza



fig. 111
polizia
municipale



fig. 112
vigili del fuoco



fig. 113
frontiera



fig. 114
stazione



fig. 115
stazione FS



fig. 116
aeroporto



fig. 117
partenze



fig. 118
arrivi



fig. 119
porto



fig. 120
traghetto



fig. 121
aliscafo



fig. 122
autostazione

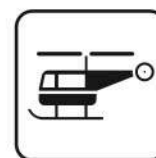

fig. 123
eliporto



fig. 124
carico e scarico



fig. 125
zona pedonale



fig. 126
attraversamento
pedonale



fig. 127
sottopassaggio



fig. 128
sovrappassaggio



fig. 129
rampa



fig. 130
invalido



fig. 131
bicicletta



fig. 132
ciclomotore



fig. 133
motociclo



fig. 134
motocarozzetta



fig. 135
motocarro



fig. 136
auto



fig. 137
autocarro



fig. 138
autotreno



fig. 139
autoarticolato



fig. 140.a
trasporto
container



fig. 140.b
rimorchio



fig. 141
autobus
urbano



fig. 142
autobus
extraurbano



fig. 143
tram



fig. 144
metropolitana



fig. 145
taxi



fig. 146
autocaravan



147
caravan



fig. 148
auto + rimorchio

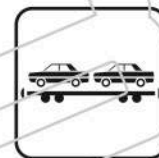

fig. 149
auto al seguito



fig. 150
cuccetta + auto



fig. 151
mezzo d'opera



fig. 152
scarico



fig. 153
autosoccorso



fig. 154
sgombraneve



fig. 155
spazzatrice



fig. 156
trattrice



fig. 157
macchina
operatrice



fig. 158
autocisterna
con prodotti
contaminanti



fig. 159
trasporto esplosivi



fig. 160
merci pericolose



fig. 161
autostrada



fig. 162
inversione di
marcia



fig. 163
rifornimento



fig. 164
benzina verde



fig. 165
gpl



fig. 166
diesel



fig. 167
metano

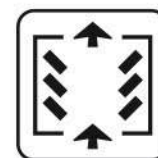

fig. 168
autorimessa



fig. 169
riparazioni



fig. 170
parcheggio



fig. 171
parchimetro



fig. 172
disco orario



fig. 173
albergo o motel



fig. 174
bar



fig. 175
ristorante



fig. 176
wc



fig. 177
uscita di
emergenza



fig. 178
estintore



fig. 179
impianto
di scarico per
autocaravan



fig. 180
camping



fig. 181
pneumatici
da neve

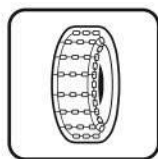

fig. 182
catene



fig. 183
asilo



fig. 184
scuola



fig. 185
università



fig. 186
chiesa

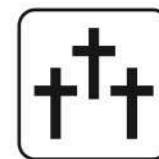

fig. 187
cimitero



fig. 188
banca



fig. 189
tribunale



fig. 190
biblioteca



fig. 191
esposizione
fiera



fig. 192
industria



fig. 193
campo boario



fig. 194
supermercato



fig. 195
cinema



fig. 196
teatro



fig. 197
discoteca



fig. 198
parco giochi



fig. 199
zoo



fig. 200
acquario



fig. 201
museo



fig. 202
terme



fig. 203
castello



fig. 204
zona
archeologica



fig. 205
grotte



fig. 206
porto
turistico



fig. 207
escursionisti



fig. 208
punto
panoramico

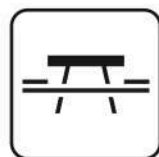

fig. 209
area pic nic



fig. 210
mare, fiume, lago



fig. 211
pineta



fig. 212
pineta + mare



fig. 213
foresta



fig. 214
cascata



fig. 215
centro
sportivo



fig. 216
stadio



fig. 217
ippodromo



fig. 218
velodromo



fig. 219
piscina



fig. 220
pallavolo



fig. 221
pallacanestro



fig. 222
tennis



fig. 223
pattinaggio



fig. 224
tiro



fig. 225
arco



fig. 226
bocce



fig. 227
golf



fig. 228
scuola sci



fig. 229
funivia



fig. 230
seggiovia



fig. 231
skilift



mod. 1.a
distanza



mod. 1.b
distanza



mod. 2.a
estesa



mod. 2.b
estesa



mod. 3.a
validità

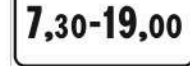

mod. 3.b
validità

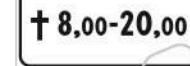

mod. 3.c
validità

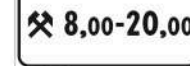

mod. 3.d
validità



mod. 4.a
limitazione e/o
eccezioni



mod. 4.b
limitazione e/o
eccezioni



mod. 5.a1
inizio



mod. 5.a2
continua



mod. 5.a3
fine



mod. 5.b1
inizio



mod. 5.b2
continua



mod. 5.b3
fine



mod. 6.a
segni orizzontali
in rifacimento



mod. 6.b
incidente



mod. 6.c
attraversamento
di binari



mod. 6.d
sgombraneve
in azione



mod. 6.e
zona soggetta
ad allagamento



mod. 6.f
coda



mod. 6.g
mezzi di lavoro in
azione



mod. 6.h
strada
sdruciolevole
per ghiaccio



mod. 6.i
strada
sdruciolevole
per pioggia



mod. 6.l
autocarri in
rallentamento

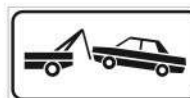

mod. 6.m
zona rimozione
coatta



mod. 6.n
segnale di corsia
coatta



mod. 6.p1.1
tornante



mod. 6.p1.2
tornante



mod. 6.p2
numero del
tornante



mod. 6.q1
pulizia meccanica
della strada



mod. 6.q2
pulizia meccanica
della strada



mod. 8.a
divieto di sosta
temporaneo

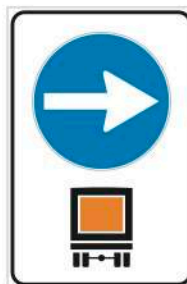

mod. 8.b
itinerario
obbligatorio merci
pericolose

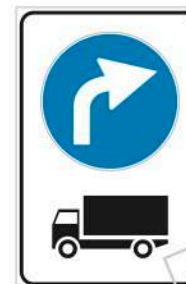

mod. 8.c
preavviso deviazione
obbligatoria autocarri
in transito



mod. 8.d
divieto di transito
autocarri



mod. 7 A
andamento
della strada
principale



mod. 7 B
andamento
della strada
principale



mod. 7 C
andamento
della strada
principale

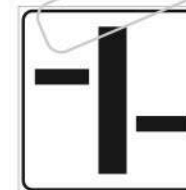

mod. 7 D
andamento
della strada
principale



mod. 7 E
andamento
della strada
principale

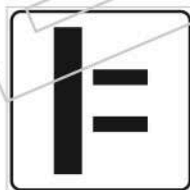

mod. 7 F
andamento
della strada
principale



mod. 7 G
andamento
della strada
principale



mod. 7 H
andamento
della strada
principale



mod. 7 i
andamento
della strada
principale



mod. 7 L
andamento
della strada
principale



art. 6059



art. 6060



art. 6061



art. 6062



art. 6063



art. 6064



art. 6065



art. 6066



art. 6067



art. 6068



art. 6069



art. 6070



art. 6071



art. 6072

articoli non inseriti nel codice della strada



art. 6038



art. 6039



art. 6040



art. 6041



art. 6042



art. 6043



art. 6044



art. 6045



art. 6046



art. 6047



art. 6048



art. 6049



art. 6050



art. 6051



art. 6052



art. 6022



art. 6023



art. 6024



art. 6025



art. 6026



art. 6027



art. 6028



art. 6029



art. 6030



art. 6031



art. 6032



art. 6033



art. 6034



art. 6035



art. 6036



art. 6037



fig. 232
segnale di selezione alto con lanterne semaforiche incorporate
obbligatorio in pellicola cl.2



fig. 233
segnale di preavviso di intersezione urbana
obbligatorio in pellicola cl.2



fig. 234
segnale di preavviso di intersezione extraurbana
obbligatorio in pellicola cl.2



fig. 235
segnale di preavviso di intersezione per diramazione autostradale
obbligatorio in pellicola cl.2



fig. 236
segnale di preavviso di intersezioni ravvicinate urbane
obbligatorio in pellicola cl.2



fig. 237
segnale di preavviso di intersezioni ravvicinate extraurbane
obbligatorio in pellicola cl.2



fig. 238
segnale di preavviso di intersezione urbana rotatoria
obbligatorio in pellicola cl.2



fig. 239
segnale di preavviso di intersezione urbana, con divieto di transito per una categoria di veicoli su un ramo della intersezione
obbligatorio in pellicola cl.2



fig. 240
segnale di preavviso di intersezione extraurbana con passaggio a livello su un ramo dell'intersezione
obbligatorio in pellicola cl.2

segnali di preselezione



fig. 241
segnale di preselezione urbano
obbligatorio in pellicola cl.2



fig. 242
segnale di preselezione urbano posto sopra la carreggiata
obbligatorio in pellicola cl.2



fig. 243
segnale di preselezione extraurbano
obbligatorio in pellicola cl.2



fig. 244

segnale di preselezione urbano
obbligatorio in pellicola cl.2



fig. 245

segnale di preselezione extraurbano
obbligatorio in pellicola cl.2



fig. 246

segnale di corsia con funzione di preavviso
obbligatorio in pellicola cl.2



fig. 247

segnale di corsia con funzione di preselezione e di direzione
obbligatorio in pellicola cl.2

segnali di direzione



fig. 248

segnale di direzione urbano
obbligatorio in pellicola cl.2



fig. 249

segnale di direzione extraurbano
obbligatorio in pellicola cl.2



fig. 250

segnali di corsia con funzione di direzione
obbligatorio in pellicola cl.2



fig. 251

segnali di corsia con funzione di direzione
obbligatorio in pellicola cl.2



fig. 252

segnali di corsia con funzione di direzione con le modalità per l'utilizzo delle singole corsie
obbligatorio in pellicola cl.2



fig. 253

gruppo segnaletico unitario urbano monofilare
obbligatorio in pellicola cl.2

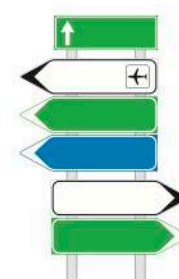

fig. 254

gruppo segnaletico unitario extraurbano
obbligatorio in pellicola cl.2

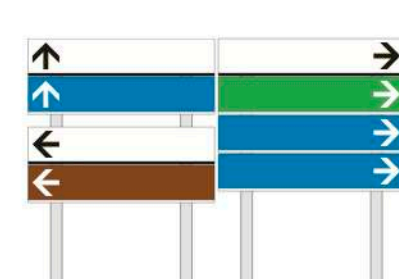

fig. 255

gruppo segnaletico unitario urbano bifilare
obbligatorio in pellicola cl.2

articoli non inseriti nel codice della strada



fig. 256
segnale identificazione itinerario internazionale



fig. 257
segnale identificazione autostrada



fig. 261
segnale di progressiva chilometrica



fig. 258
segnale identificazione strada statale



fig. 259
segnale identificazione strada provinciale



fig. 260
segnale identificazione strada comunale



fig. 262
segnale di progressiva ettometrica



art. 262 A
cippo ettometrico bifacciale scatoletto e rivettato (alluminio 10/10 completo di paletti laterali in tubolare mm 15x35 verniciato)

art. 262 B
cippo ettometrico bifacciale scatoletto e rivettato (alluminio 10/10 completo di paletto centrale in tubolare da mm 15x35 verniciato)

art. 262 C
cippo ettometrico bifacciale scatoletto e rivettato con attacco al guard-rails (alluminio 10/10 completo di paletto laterale in tubolare da mm 15x35 con staffa regolabile, verniciato)

art. 262 D
cippo ettometrico bifacciale (alluminio 25/10) predisposto per attacco al new jersey. Fissaggio consigliabile: tasselli ad espansione in acciaio ø 8 mm (non inclusi)



fig. 263
progressiva distanziometrica autostradale



fig. 264
progressiva distanziometrica autostradale



fig. 265
progressiva distanziometrica integrata con segnale di conferma su strade extraurbane



fig. 266
progressiva distanziometrica per strada statale



fig. 267
progressiva distanziometrica per strada provinciale



fig. 268
progressiva distanziometrica per strada comunale



fig. 269
numero di identificazione autostrada+freccia con funzione di direzione



fig. 270
numero identificazione strada statale+freccia e strada comunale+freccia con funzione di direzione



fig. 271
numero identificazione strada provinciale+freccia con funzione di direzione



fig. 272
segnale di itinerario extraurbano



fig. 273
inizio centro abitato



fig. 274
fine centro abitato



fig. 275
segnale di inizio e fine regione



fig. 276
segnale di inizio e fine provincia



fig. 276 A
segnale relativo alla numerazione dei cavalcavia sulle autostrade



fig. 276 B
segnale relativo alla numerazione dei cavalcavia sulle strade extraurbane e statali



fig. 276 C
segnale relativo alla numerazione dei cavalcavia sulle strade provinciali



fig. 276 D
segnale relativo alla numerazione dei cavalcavia sulle strade comunali

Direttiva del Ministero LL.PP. del 28/02/1997 n° 1156

segnali di localizzazione

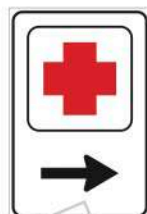

fig. 277
pronto soccorso



fig. 278
stazione



fig. 279
polizia

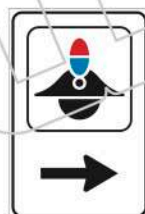

fig. 280
carabinieri



fig. 281
informazioni



fig. 282
ospedale



fig. 283
comune



fig. 284
polizia municipale



fig. 285
segnale di conferma autostradale



fig. 286
numero identificazione autostrada+freccia verticale con funzione di conferma

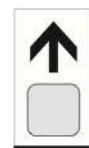

fig. 287
segnale di conferma urbano



fig. 288
segnale di conferma urbano

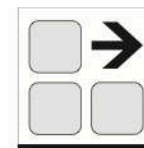

fig. 289
segnale di conferma urbano

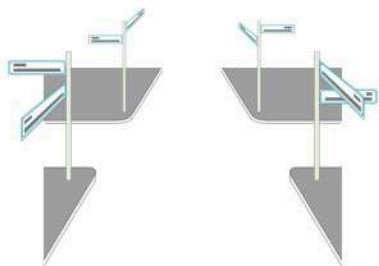

fig. 291
segnale nome-strada applicato in angolo

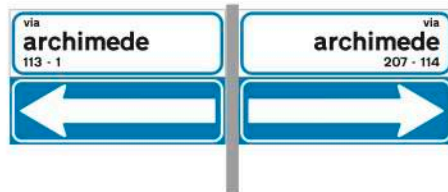

fig. 292
segnale nome-strada combinato col senso unico e numeri civici



fig. 293
numero civico perpendicolare all'asse stradale



fig. 294
segnali turistici e di territorio



fig. 295
segnale di localizzazione territoriale



fig. 296
segnale di avvio alla zona industriale

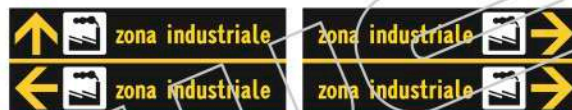

fig. 297
segnali di direzione per le industrie

segnaletica alberghiera

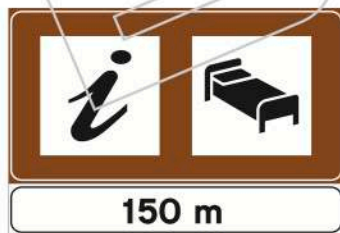

fig. 298
preavviso di informazioni turistico alberghiere
obbligatorio in pellicola cl.2



fig. 299
segnale di informazioni alberghiere
obbligatorio in pellicola cl.2

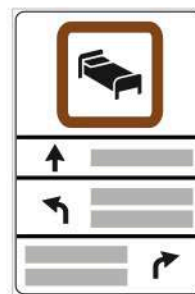

fig. 300
segnale di preavviso alberghiero
obbligatorio in pellicola cl.2

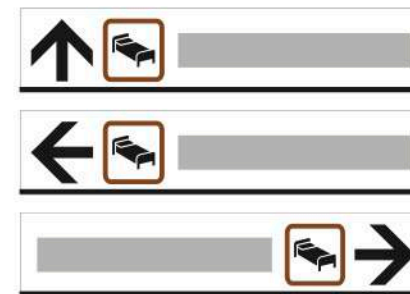

fig. 301
segnali di direzione alberghieri
obbligatorio in pellicola cl.2

articoli non inseriti nel codice della strada



fig. 302
ospedale



fig. 303
attraversamento
pedonale



fig. 304
scuolabus



art. 6053



art. 6054

targhe in alluminio 20/10 bifacciale rivettato
con staffoni ø 60 in alluminio estruso



fig. 305
sos



fig. 306
sottopassaggio
pedonale



fig. 307
sovrappassaggio
pedonale



fig. 308
rampa inclinata
pedonale



fig. 309
strada senza
uscita



fig. 310
preavviso di strada
senza uscita



fig. 311
preavviso di strada
senza uscita



fig. 312
velocità consigliata



fig. 313
fine velocità
consigliata



fig. 314
strada riservata ai
veicoli a motore



fig. 315
fine strada
riservata ai veicoli
a motore



fig. 316
galleria



fig. 317
ponte



fig. 318
zona residenziale



fig. 319
fine zona
residenziale



fig. 320 A
area pedonale



fig. 320 B
pannello integrativo



fig. 321
fine area pedonale



fig. 322 A1
zona a traffico limitato



fig. 322 A2
pannello integrativo

articoli non inseriti nel codice della strada



fig. 322.b
fine zona a traffico limitato



fig. 323.a
zona a velocità limitata



fig. 323.b
fine zona a velocità limitata



fig. 324
attraversamento ciclabile

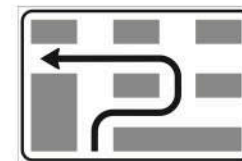

fig. 325
svolta a sinistra semidiretta



fig. 326
svolta a sinistra indiretta



fig. 327
inversione di marcia



fig. 328
piazzola su viabilità ordinaria



fig. 328 v
piazzola su viabilità ordinaria



fig. 329
piazzola + sos autostradale



fig. 330
transitabilità



art. 6055



art. 6056



art. 6057



art. 6058

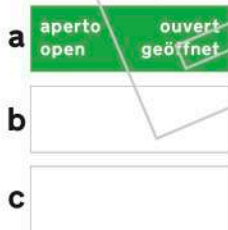

fig. 331
via libera

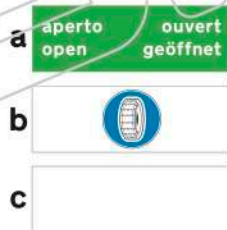

fig. 332
via libera con obbligo di catene e pneumatici da neve

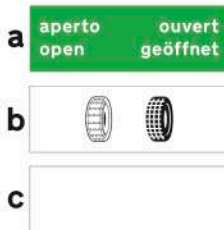

fig. 333
via libera con catene o pneumatici da neve raccomandati



fig. 334
strada intransitabile



fig. 335
tratto terminale della strada o passo chiuso



fig. 336
tratto terminale della strada o passo chiuso



art. 2204
lato 60 cm - all. cl.1



art. 2206
lato 60 cm - all. cl.1

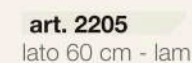

art. 2205
lato 60 cm - lam. cl.1



art. 2207
lato 60 cm - lam. cl.1

articoli non inseriti nel codice della strada



fig. 337
uso corsie



fig. 338
uso corsie



fig. 339
uso corsie

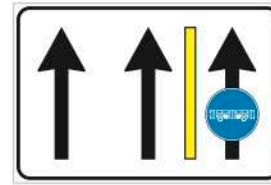

fig. 340
uso corsie



fig. 341
variazione corsie
disponibili



fig. 342
variazione corsie
disponibili



fig. 343
variazione corsie
disponibili



fig. 344
variazione corsie
disponibili



fig. 345
inizio autostrada



fig. 345 B
inizio strada
extraurbana
principale



fig. 346
fine autostrada



fig. 346 B
fine strada
extraurbana
principale



fig. 347
preavviso di inizio
autostrada



fig. 347 B
preavviso di inizio strada
extraurbana principale



fig. 348
senso unico
parallelo



fig. 349
senso unico
frontale

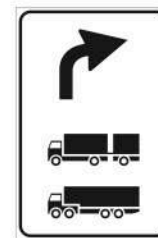

fig. 350
preavviso deviazione
consigliata autocarri
in trasporto



fig. 351
direzione autocarri
consigliata



fig. 352
limiti di velocità
generali



fig. 353
pronto soccorso



fig. 354
assistenza
meccanica



fig. 355
telefono



fig. 356
rifornimento



fig. 357
rifornimento



fig. 358
fermata autobus



fig. 359
fermata tram



fig. 360
informazioni



fig. 361
ostello per la
gioventù



fig. 362
area pic nic



fig. 363
campeggio



fig. 364
radio
informazioni
stradali



fig. 365
motel o
albergo



fig. 366
bar



fig. 367
ristorante



fig. 368
parcheggio di
scambio con
linee autobus



fig. 369
parcheggio di
scambio con
tram



fig. 370
parcheggio di
scambio con
metropolitane
e/o altri servizi
extraurbani su
rotaia



fig. 371
parcheggio di
scambio in
corrispondenza di
itinerari turistici e/o
escursionistici a
piedi



fig. 372
auto su treno



fig. 373
auto al seguito

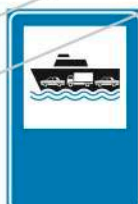

fig. 374
auto su nave



fig. 375
taxi



fig. 376
area di servizio



fig. 377
area attrezzata
con impianti di
scarico



fig. 378
polizia stradale



fig. 379
polizia di stato



fig. 380
carabinieri



fig. 381
guardia di
finanza